

Suggested maximum 4 in. w.g. differential pressure

Standard Construction and Materials

- FRAME:** .080" thick (nominal) extruded aluminum, 7½" deep.
- BLADE:** .080" thick (nominal) extruded aluminum, reinforced for frames over 18" dia.
- SHAFT:** ½" dia. extruded aluminum.
- BEARINGS:** Flange Oilite Bronze.
- SEALS:** On frame, ¼" thick closed cell neoprene. Temperature range is -35°F to 180°F.
- CONTROL ROD:** Cadmium plated steel.
- FINISH:** Mill.

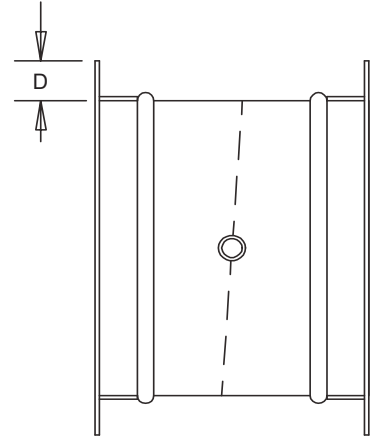

Equal Leg Angles are available. They are welded to frames at intermittent spacing and caulked between welds. Flange Height "D" varies with Damper Diameter.

Notes

1. Dampers are available in 1" increments only.
2. Please contact the factory for damper sizes larger than 36" diameter.
3. To calculate approximate shipping weight (lbs./in.), use following formula:
 Damper Circumference (Diameter [in.] × 3.141) × 0.3

Damper Sizes

Minimum Size	Maximum Size
4" O.D.	36" O.D.

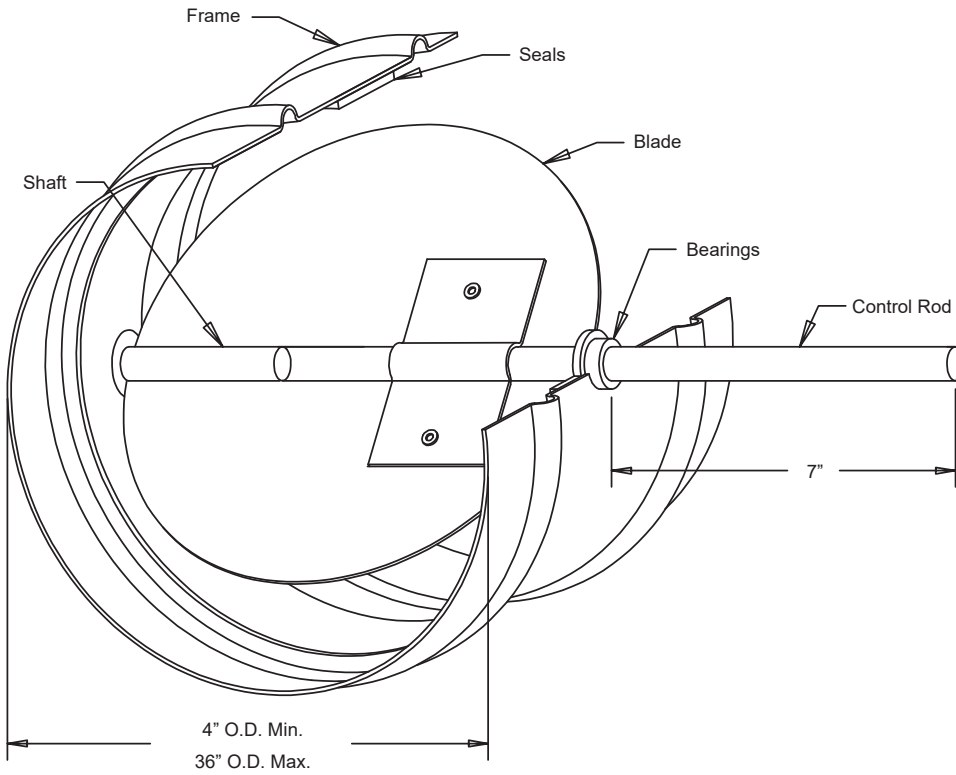

Please inquire for larger sizes.

					 Union Made		
Item #	Qty	Damper Size O.D.	Tagging				
Arch. / Eng.:			EDR:		ECN:		Job:
Contractor:							
Project:			Date:		DWN:		DWG:

In the interest of product development, Cesco Products reserves the right to make changes without notice.



450 Riverside Dr • Wyalusing PA, 18853
 Phone: 570-746-1888 • Fax: 570-746-9286
 www.cescoproducts.com

Pressure Drop Data

Pressure Drop Ratings are based on AMCA Standard 500 using test set-up 5.3 for Dampers installed with Duct Upstream and Downstream. Static Pressures are corrected to 0.075 lb./cu.ft. air density.

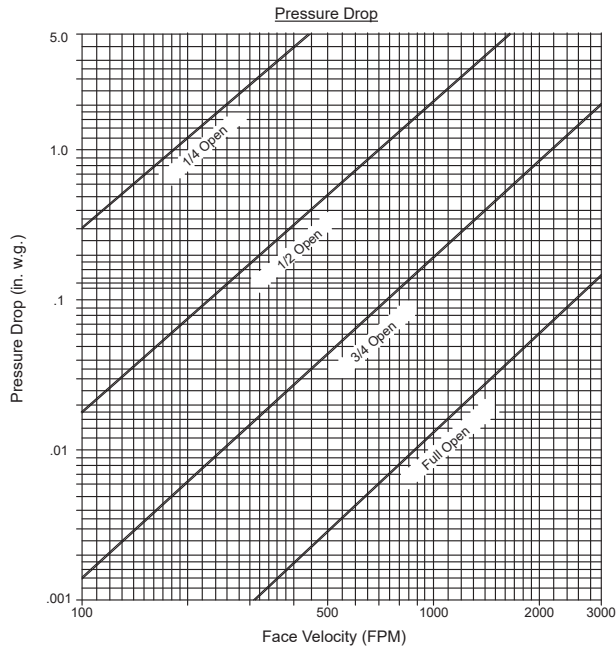

Air Leakage Data

Air Leakage Ratings are based on AMCA Standard 500 using test set-up 5.4. Air Leakage is corrected to 0.075 lb./cu.ft. air density.

